

ERRE Modelling with Constraints

Byron Weber Becker¹ and Antony Hodgson
17-November-2016

Executive Overview

On 19-Oct-2016 I presented the results of modelling many of the electoral systems proposed for Canada to the House of Commons Special Committee on Electoral Reform. The next day the Committee asked me to develop MMP, STV, and RU-PR models that respect a specific set of constraints:

1. Composite Gallagher scores that are as low as possible.
2. Each province and territory must have exactly the same number of MPs as allocated in the distribution used in the 2015 election.
3. Redistribution of seats, if necessary, must be able to be carried out quickly by merging existing ridings in sets of two, three, or more.

This report is the summary of my work to achieve these goals. Briefly, I have models for MMP, STV, and a new variant of RU-PR that have composite Gallagher scores that are well below 5 and often below 3 and that respect the constraints set out by the Committee.

I believe that any of the systems contained herein could work well for Canada. There are, however, significant trade-offs between them that will need careful consideration before choosing one.

A Modelling Framework

All three requested models can fit into a consistent framework that also includes FPTP (First-Past-The-Post), AV (Alternative Vote), and a slightly modified version of RU-PR that I'll call Riding-Centric RU-PR, or RC Proportional (RCP) for short. Reviewing that framework will be useful as we discuss the effects of the constraints imposed by the Committee.

All of the voting systems considered here refer to either or both of a riding or a region. Some systems are composed entirely of ridings, whether single- or multi-member (e.g. FPTP, AV, STV and RCP), while others are of a mixture including both

¹ Antony Hodgson, the President of Fair Voting BC, was an important resource in brainstorming models and crafting words and pictures to describe them. The core idea behind the Riding Centric Proportional model is inspired by Leonid A. Elbert of Moncton, NB, via his *Local Transferable Vote* submission to the ERRE. I take full responsibility for modelling the ideas that came forward in these conversations and the final result of this work.

ridings and regions (e.g. MMP and RU-PR). The terms 'riding' and 'region' refer to geographic areas that MPs have primary responsibility to represent and serve. A riding is the most local area; a region generally encompasses at least several ridings.

In general, MPs are elected primarily on the basis of votes cast in the corresponding riding or region, though the different systems have some slight tweaks that can enable voters from outside the riding or region to have some influence on the outcome within a riding (for example, although we don't discuss it here, the Dual Member Proportional system being proposed in Prince Edward Island assigns the second seat in each two-member riding in part on the basis of votes cast across the province).

The following diagrams therefore show one row indicating how the ridings are arranged and, if applicable, a row above the riding showing how the regions are arranged, including how the MPs are assigned to either the ridings or the regions. In addition, we use solid bars to indicate the areas over which votes can contribute to electing specific MPs. Note that we are assuming that all ridings and regions fit within provincial boundaries and that we are not using votes cast in one province to affect the outcome of electoral contests in other provinces.

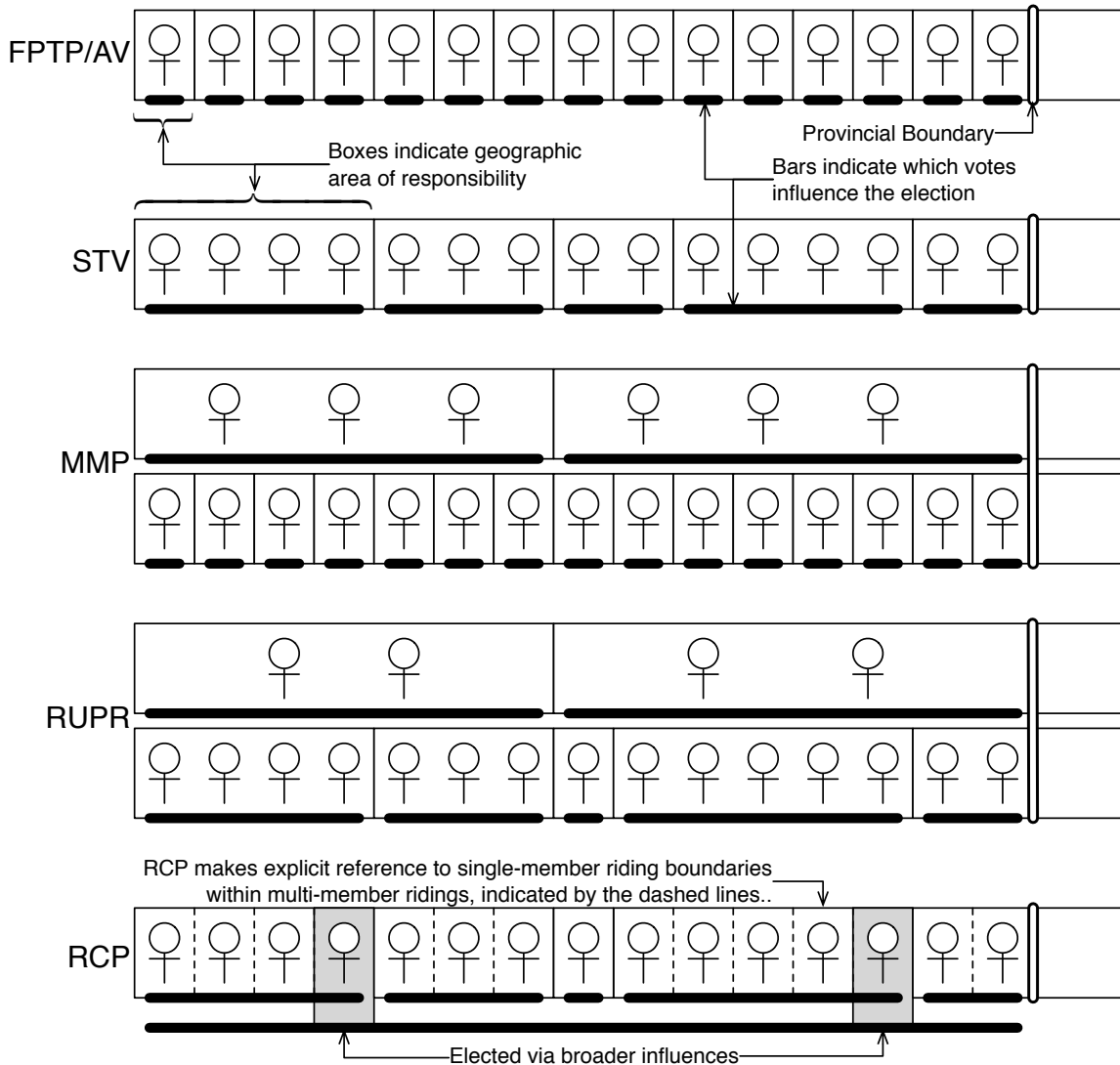

Figure 1: Riding and region configurations for various electoral models

Majoritarian Systems (e.g. FPTP, AV)

Majoritarian systems use single member ridings of roughly equal population per riding that are allocated within provincial boundaries (though population per riding can vary significantly between provinces). This is illustrated in Figure 2 – each riding elects one MP based only on the votes from within that riding. Because one MP cannot represent the political perspectives of all voters, many votes (on average, half) have no influence on the outcome.

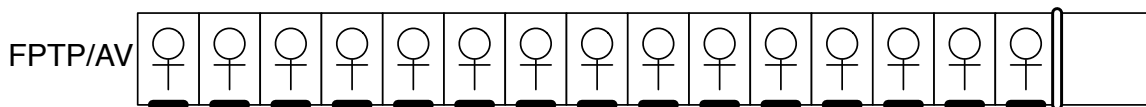

Figure 2: Riding configuration for FPTP and AV

Ballots can be counted in the ridings using either FPTP or AV.

This system can be generalized in two independent ways to increase proportionality: by increasing the number of MPs in each riding (leading to systems like STV) and by adding a compensatory layer (leading to systems like MMP).

Multi-Member Systems (e.g. Single Transferable Vote)

Multi-member systems such as the Single Transferable Vote and Open List group MPs together into multi-member ridings, as shown in Figure 3. In general, more than one MP is elected in each riding, normally based solely on votes cast within that riding, as indicated by the solid bar. MPs are expected to represent and serve their entire riding.

These systems provide a diversity of political perspectives at the riding level and have high direct representation scores (typically 80-90+% of the voters have voted directly for one of the MPs). However, since the results within each riding are independent of those in other ridings around the province, the provincial disproportionality (as assessed by the Gallagher Index) is typically somewhat higher than compensatory or mixed systems (see next section) that consider votes cast over a larger area. The Gallagher Index is normally improved by increasing the number of MPs per riding (typically referred to as ‘district magnitude’).

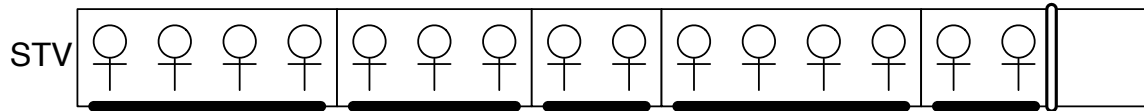

Figure 3: Riding configuration for multi-member systems

Multi-member systems naturally conform to the constraints given by the Committee. The multi-member ridings can be combined by simply merging existing ridings as dictated by areas of common interest and natural boundaries.

I previously modelled STV with small and medium sized multi-member ridings. I recently added a variant with huge ridings, equal to the size of the entire province, to show the limits of STV’s proportionality in a Canadian context. These results are summarized in Table 1:

Description	Average District Magnitude	Composite Gallagher Score
Small multi-member ridings	4.1	6.5
Medium sized multi-member ridings	10.9	4.3
Huge multi-member ridings (ranging from 4 to 121 seats)	26.0	2.4

Table 1: Summary of STV systems

While the proportionality of the huge ridings option is certainly acceptable, few would call the ballots for such large ridings “workable”. Backing off to the medium-sized ridings starts to favour large, centrist parties at the expense of geographically disperse small parties and still leaves us with huge geographical ridings in sparsely populated areas.

It is worth noting that my STV modelling is based on assumptions of how votes transfer between candidates as they are dropped or elected. I’ve based such transfers on the best polling data I could find (an Ekos poll from just before the 2015 election), but in my mind it still represents the weakest assumption in my modelling efforts.

One way of dealing with this would be to run the models several times, each with a different set of assumptions of how votes transfer. We could then see how sensitive the results are to changes in transfers, much as I do with swinging votes between parties. It’s not at all hard to make those changes. The harder part is making sense of the results.

Compensatory Systems (e.g. Mixed Member Proportional and Rural-Urban PR)

Mixed systems have a riding layer, as described above, but attempt to improve the Gallagher Index by adding compensatory seats in a regional layer that is normally larger than any riding (single or multi-member) that lies within the region.

Mixed Member Proportional

A Mixed Member Proportional system is shown in Figure 4. The bottom row shows the 15 single-member ridings while the top row shows two regions (in this province), each with three MPs in compensatory seats.

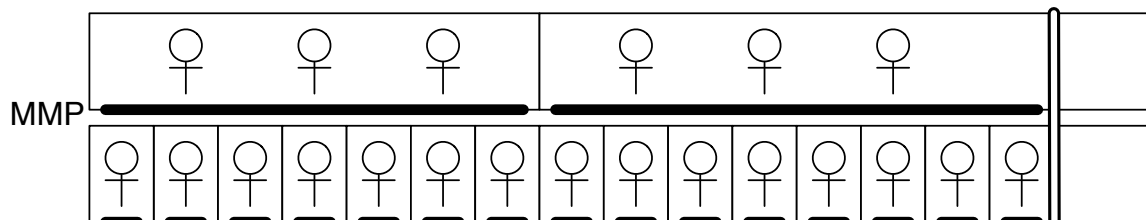

Figure 4: Riding and region configuration for MMP

The key feature here is that the ridings are all single-member. If we are to preserve existing riding boundaries and not increase the number of seats, the only practical option is to pair two existing ridings, elect one MP in the now-paired riding and free up one seat for the regional level.

I have modelled this with three different sizes at the region level and using both FPTP and AV for elections in the ridings. The resulting composite Gallagher scores are shown Table 2.

Description	Composite Gallagher with FPTP	Composite Gallagher with AV
Small Regions: Split each of the regions in Large Regions (see the next section) that are 12 seats or larger into two regions. The average is 7.1 seats per region (counting both the riding level and the region level, half at the riding level and half at the region level). The average province has 4.7 regions.	3.7	3.5
Large Regions: Each province has 1 or more regions with no region having more than 14 seats (7 at the riding level and 7 at the region level). The overall average is 12.9 seats per region. The average province has 2.6 regions.	2.3	2.5
Provincial Regions: Each province has only one region, averaging 33.5 seats, but varying from 4 (PEI) to 121 (Ontario)	1.8	1.8

Table 2: Summary of MMP systems

Having province-wide regions eliminates the possibility of an open list system in the larger provinces – the ballots would simply be too large. An open list would still be possible with the Large Regions model.

I see little reason to put up with the huge region sizes in Ontario and Quebec that are implied by the Provincial Regions model. On the other hand, Small Regions is showing a decided bias against geographically disperse parties such as the Greens. I would be uncomfortable recommending it. Furthermore, this is not the result of the constraints imposed by ERRE. Previous modelling, which did not have these constraints, shows much the same result.

A variant of this model groups 3 current ridings into 2, which frees up one seat for the regional level; this results in 33% regional seats and 67% riding seats, so each riding would be 50% larger than at present and the Electoral Boundaries Commission would have to redraw the boundary within each set of three current ridings. Unfortunately, I have not yet had time to model this variant. However, given that proportionality decreases as we decrease seats at the regional level and increase them at the riding level, this does not seem like a promising approach.

Rural-Urban Proportional

The Rural-Urban PR model is shown in Figure 5. It features a mix of single-member and multi-member ridings in the first tier and a smaller number of regional seats than with MMP (due in large part to the increased proportionality at the riding level arising from the use of multi-member ridings). I have found that the RU-PR model typically requires about half the number of regional seats as MMP requires for similar levels of the Gallagher Index. The RU-PR model can accommodate some single-member

seats, provided that they are included within a region sufficiently large to compensate for any disproportionality arising in these single-member seats; any such single-member ridings will be slightly increased in size (~15%) compared with existing ridings. As with MMP, the electoral threshold is directly related to the total number of seats in a region.

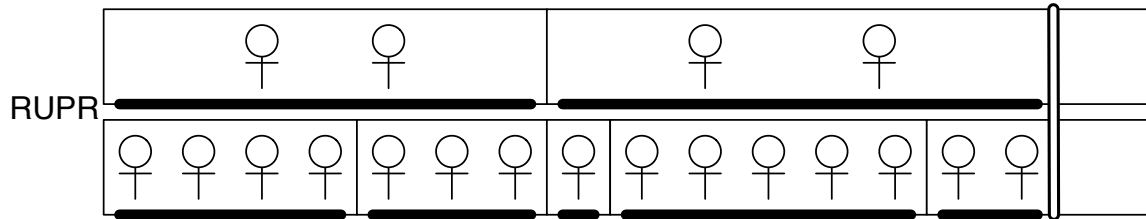

Figure 5: Riding and region configuration for RUPR

Unfortunately, the RU-PR model as outlined above cannot be directly implemented with the constraints given by the ERRE Committee. To create the seats at the regional level we need to either expand riding boundaries or we must enlarge the House of Commons. However, the following section briefly describes a variant model that behaves very much like RU-PR, but which also satisfies the constraint that we use existing electoral boundaries.

Riding-Centric Proportional Representation (RCP)²

We can create a version of the RU-PR model that works within the Committee’s constraints if we make a relatively simple adjustment to how we treat the regional (compensatory) seat. Instead of explicitly freeing up a compensatory seat by removing it from the riding level, we simply designate some larger multi-member ridings as ‘adjustment’ ridings (the remaining smaller ridings will have no adjustment seats in them).

An adjustment riding includes one seat that is filled with reference to the votes from the entire province (the lower heavy bar in Figure 6) rather than only the votes from the multi-member riding (the upper heavy bar). The goal is to increase the natural proportionality of multi-member ridings even further.

I call this variant Riding-Centric Proportional, or RCP. It is described in more detail in Appendix 1.

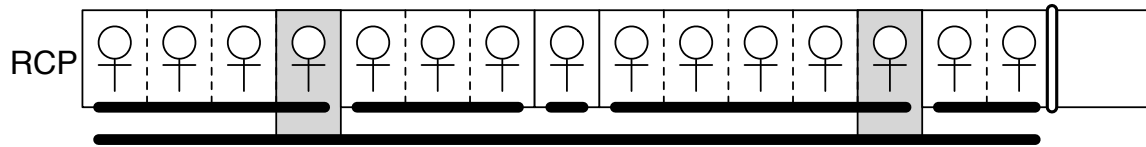

Figure 6: Riding configuration for RCP

² The name “Mixed Multi-Member Proportional” or M³P has been suggested to show its relationship to both MMP and multi-member systems like STV.

Note that in this figure there are dashed lines between the MPs in the multi-member ridings. They represent single-member 'sub-ridings' embedded within the multi-member riding. Until the next full redistricting, these would correspond to our current (2015) ridings. A small tweak to the counting rules in the multi-member ridings can also guarantee that one MP is elected from each of the single-member sub-ridings. If the Committee wishes to provide this feature, all voters could continue to have a single MP identified with their current riding whom they can approach for constituency service issues, while still enabling all voters in the riding to have their policy perspectives represented by at least one MP. Usually that MP will be in their own multi-member riding, but occasionally it will be through an adjustment seat outside their own riding.

We elect MPs from the smaller ridings just as with the original version of RU-PR, along with all but one of the seats in each adjustment riding. The final seat in each of the adjustment ridings (the 'adjustment seats') are given in sequence to the top remaining candidate from the most under-represented party in each round based on the party vote shares determined from first preferences on the ballot in each region or province. This ensures that the most under-represented parties obtain their adjustment seats in regions where they are relatively strongest.

As with all other proportional voting systems, the electoral threshold is determined by the size of the compensatory region (which can easily be made province-wide with RCP). The Gallagher Index can be reduced by increasing the riding sizes (as with STV), minimizing the number of single-member seats, or by increasing the percentage of adjustment seats.

In practice, as with RU-PR, we find that having approximately 15% adjustment seats (depending on the number of single-member seats) leads to excellent Gallagher Index scores. The direct and indirect representation scores are similar to that of RU-PR.

The following table gives several examples. The model is very flexible and many more variations could be developed.

Description	% Multi-Member Ridings	Avg. Seats Per Riding	% (#) Adjustment Seats	Composite Gallagher Index
Mostly multi-member; few adjustment seats	95%	3.8	11% (37)	2.4
Mostly multi-member; more adjustment seats	95%	3.6	15% (51)	2.0
Mostly multi-member (but not quite as many as above); many adjustment seats	89%	3.2	21% (70)	1.8
More single-member ridings; more adjustment seats	37%	2.0	13% (45)	5.6

More single-member ridings; no adjustment seats (similar to Kingsley's proposal)	38%	2.3	0% (0)	10.7
--	-----	-----	--------	------

The third option – mostly multi-member ridings with many adjustment seats – has an excellent composite Gallagher score of 1.8. Based on the 2015 data, the NDP, Bloc, and Greens each receive their fair share of seats to within ½ a seat. The Liberals have two extra seats and the Conservatives one while fringe parties and independents do not get an seats.

Furthermore, the vote swing analysis shows that this is remarkably stable across different voting patterns. Recall that these graphs have two lines for each party that ideally coincide everywhere. This graph very nearly meets that ideal.

Voters shift between Conservative and Liberal

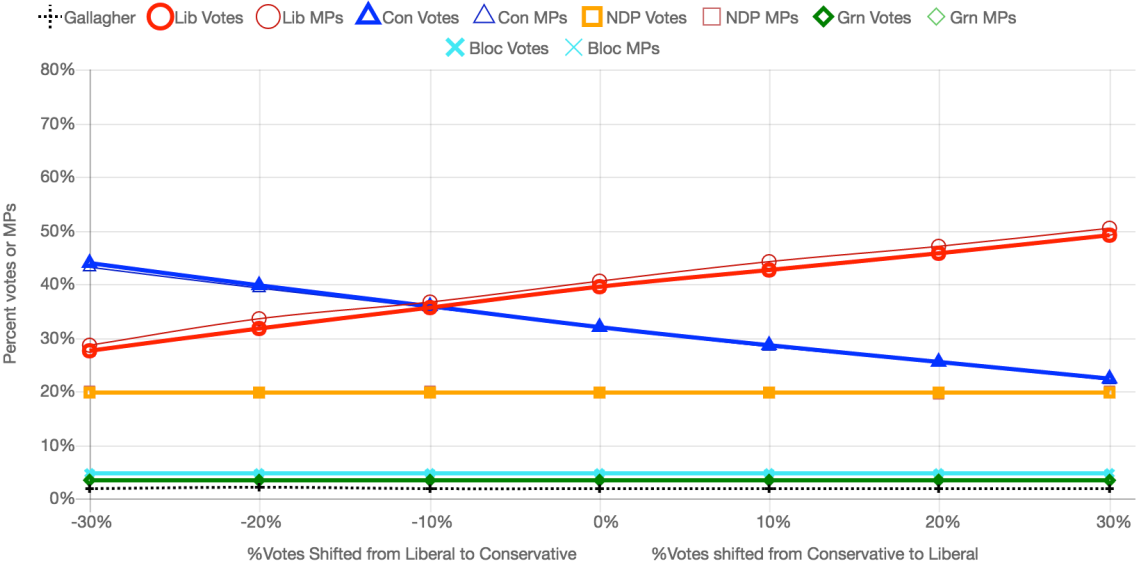

The options with only 10% and 15% adjustment seats are also excellent. On the 10% model, for example, the Greens and Bloc receive 10 and 14 seats rather than 11 and 15 while the Liberals receive 139 instead of 137.

However, there are disadvantages to this model. I think there would be a fair amount of grumbling regarding the adjustment seats. Because the specific MP elected to the seat comes from a specific riding, their first preference votes can be directly compared to the other candidates in the riding. Lost in that comparison is the fact that they represent support from multiple multi-member ridings.

For example, consider the simulated results for what would be my home multi-member riding of Kitchener-Waterloo. It would include the four current ridings of Kitchener Centre, Kitchener-Conestoga, Kitchener South-Hespeler, and Waterloo.

Simulating the RCP rules on the candidates that ran in 2015 gives the results shown below in Table 3. The first three winners (Chagger, Saini, Albrecht) are easily accepted. They got more votes than anyone else. But why is David Weber, a

Green, elected with only 1,767 votes when there are four NDP candidates all having more first choice votes but none of whom were elected? Furthermore, why is a Green elected when their combined vote in this riding is only 6,391 and 3 of the 4 NDP candidates have more first choice votes?

The answer, of course, is that the Green support is geographically dispersed. Their support across the province deserves 3 seats. The MPs to fill those seats must come from somewhere. But under this model no matter where they come from, direct comparisons like this will be inevitable.

It can also be worse than this: the person elected to the adjustment seat isn't necessarily that party's candidate with the most votes in the riding. That's due to the restriction that each candidate comes from a different 2015 riding (which is indicated by the number before each candidate's name in Table 3).

Candidate	Party	First Choice Votes	Votes + Transfers	Elected
2-Albrecht, Harold	Con	20,649	75,760.7	✓
4-Chagger, Bardish	Lib	29,752	58,813.1	✓
1-Saini, Raj	Lib	25,504	54,565.1	✓
4-Braid, Peter	Con	19,318	37,214.9	
4-Freeman, Diane	NDP	8,928	31,107.0	
2-Louis, Tim	Lib	20,398	27,477.2	
3-GagnУЉь, Marian	Con	17,544	23,005.1	
3-Tabbara, Marwan	Lib	20,215	20,470.6	
1-Woodworth, Stephen	Con	15,872	15,999.8	
1-Cadell, Susan	NDP	8,680	15,429.5	
3-Bruce, Lorne	NDP	7,440	9,459.7	
3-Weber, David	Grn	1,767	6,391.0	A
2-Villeneuve, James	NDP	4,653	4,653.0	
4-Walsh, Richard	Grn	1,713	3,168.5	
1-Wendler, Nicholas	Grn	1,597	2,035.0	
3-Lajeunesse, Nathan	Lbt	772	1,972.0	
2-Jonkman, Bob	Grn	1,314	1,314.0	
2-Hodgson, Richard	Lbt	685	942.5	
1-Miladinovic, Slavko	Lbt	515	515.0	
1-Ichim, Julian	M-L	112	203.0	
4-Hawley-Yan, Emma	Oth	138	138.0	
3-Baetz, Elaine	M-L	91	91.0	

Table 3: RCP results from simulating KW with 2015 data

A second issue is that counting the ballots quickly and reliably would require automated systems.

Relaxing Constraints

A number of observers have contacted me to inquire about the Committee's motion and the specifics of the constraints. These observers have all been of the opinion that the constraints are unneeded. The general response has been that the previous government changed the number of seats each province is entitled to without significant complaint. Of course, they obeyed well-entrenched ground rules.

Furthermore, redistricting is a regular occurrence after each census. Elections Canada has indicated they can get the job done if the Committee sticks to the agreed upon schedule.

Ryan Campbell, one of the people who contacted me, wrote:

If the quotient for the larger provinces was cut from 111,166 to 98,000, and the minimum representation set to 1985 numbers + 1, you'd get the following seat distribution. [This implies] 380 seats – or 42 new ones. A little over 12%. The ratio between the regions stays virtually unchanged.

	Current MPs	Future MPs	Current %	Future %
ON	121	137	36.1%	36.3%
QC	78	88	23.3%	23.3%
AB	34	39	10.1%	10.3%
BC	42	47	12.5%	12.5%
SK	14	15	4.2%	4.0%
MB	14	15	4.2%	4.0%
NS	11	12	3.3%	3.2%
NB	10	11	3.0%	2.9%
NL	7	8	2.1%	2.1%
PEI	4	5	1.2%	1.3%

Following Ryan's suggestions, I modelled a Rural-Urban system with mostly multi-member ridings but I applied the "tweak" from Riding-Centric Proportional to force the election of an MP in each of the 338 current ridings. The system has these desirable properties:

- An excellent composite Gallagher Index of 2.19. This could be improved even further by redistricting the smaller provinces that currently are modelled with only one compensatory seat (Manitoba, New Brunswick, Newfoundland & Labrador, Nova Scotia, PEI, and Saskatchewan).
- An MP in each of our current ridings.
- Redistricting that can be carried out quickly and easily by joining existing ridings into multi-member ridings.
- Only 11% compensatory seats (compared with 50% for the MMP system that meets all of the Committee's constraints).
- Regions that have five compensatory seats or fewer, with only one exception (which has 6).
- The negative optics of Riding-Centric Proportional are avoided because compensatory seats are not from a specific riding.

This system is listed in Table 4 on page 13 with the unimaginative name of "ru_multiples_rc2".

Conclusions

I have modelled how MMP, STV, and a variant of Rural-Urban Proportion that respect the Committee's constraints might have performed in the 2015 elections as well as simulated elections in which votes shift between parties. I remind the Committee of the usual caveats associated with this kind of modelling – the results are based on some assumptions about how people would have voted that are likely incorrect, and voter behaviour will almost certainly change if a new voting system were put in place. Nonetheless, I feel that the results reasonably and fairly reflect how each voting system would translate votes into seats had voters voted the way they had in 2015.

More importantly, the "vote swing analysis" that I described in my presentation to the Committee on 19-October-2016 convinces me that these systems are all "well-behaved". That is, they will give proportional results in a wide variety of situations.

Of the systems that meet the ERRE's constraints of a low composite Gallagher index, 338 MPs, and easy redistricting, I think that Riding-Centric Proportional (RCP) and MMP with larger region sizes best meet Canada's needs. Both of them treat currently elected parties fairly across a wide variety of electoral situations. Both can be implemented with relatively simple ballots. Both give elect a specific MP to each riding, although MMP's ridings would be twice as large as RCP's.

However, I think that even better systems are available. That assessment hinges on the belief that we can either add MPs to the House or redistrict in time for 2019. Of course, the Committee has better sources of information than I, but I do urge the Committee to be certain that those constraints really are necessary before limiting its choices so severely.

Please advise if I can be of any further assistance in running additional simulations or explaining any of the simulations discussed in this document.

Appendix: Descriptions of Systems

Describing complex systems with many parameters is hard! This table will take some digging, but captures much of each system.

Each system is described with two rows. The top row contains information about the regions. The lower row contains information about the ridings. This corresponds to the diagrams shown in Figure 1 on page 3.

The left column contains the name of the riding's design (e.g. "erre_mmp5050_ProvRegions") which is a very brief summary of how the system is set up. In this case, it's an MMP system where top-up seats come from twinning existing ridings (50-50) and each region covers the entire province. Immediately below the name is the election process used. For example, MMP_FPTP is an MMP design that uses FPTP in single member ridings.

The names of the systems I consider most interesting are in bold (e.g. **erre_mmp5050_LargeRegions**).

Table 4: Summary of electoral system models

Region		# Tot Seats	% Seats	Avg # Seats/Region	Avg #Reg/Prov	Avg Adjust Seats / Region	
Riding	Year	# Tot Seats	% Seats	Avg # Seats/Riding	% Single	% Multiple	Comp. Gallagher
erre_mmp5050_LargeRegions		166	49%	12.9	2.6		
MMP_AV	2015	172	51%	1.0	100%	0%	2.5%
erre_mmp5050_LargeRegions		166	49%	12.9	2.6		
MMP_FPTP	2015	172	51%	1.0	100%	0%	2.3%
erre_mmp5050_ProvRegions		166	49%	33.5	1.0		
MMP_AV	2015	172	51%	1.0	100%	0%	1.8%
erre_mmp5050_ProvRegions		166	49%	33.5	1.0		
MMP_FPTP	2015	172	51%	1.0	100%	0%	1.8%
erre_mmp5050_SmallRegions		166	49%	7.1	4.7		
MMP_AV	2015	172	51%	1.0	100%	0%	3.5%

Region		# Tot Seats	% Seats	Avg # Seats/Region	Avg #Reg/Prov	Avg Adjust Seats / Region	
Riding	Year	# Tot Seats	% Seats	Avg # Seats/Riding	% Single	% Multiple	Comp. Gallagher
erre_mmp5050_SmallRegions		166	49%	7.1	4.7		
MMP_FPTP	2015	172	51%	1.0	100%	0%	3.7%
erre_ru_multiples_10pct		37	11%	33.5	1.0	3.7	
RcRUPR	2015	301	89%	3.8	5%	95%	2.4%
erre_ru_multiples_15pct		51	15%	33.5	1.0	5.1	
RcRUPR	2015	287	85%	3.6	5%	95%	2.0%
erre_ru_multiples_20pct		70	21%	33.5	1.0	7.0	
RcRUPR	2015	268	79%	3.2	11%	89%	1.8%
erre_ru_singles		45	13%	33.5	1.0	4.5	
RcRUPR	2015	293	87%	2.0	63%	37%	5.6%
erre_ru_singles		45	13%	33.5	1.0		
STVplus	2015	293	87%	2.0	63%	37%	5.6%
erre_ru_singles		45	13%	33.5	1.0		
FptpList	2015	293	87%	2.0	63%	37%	2.9%
fptp		0	0%	0.0	1.0		
MMP_AV	2015	338	100%	1.0	100%	0%	24.0%
fptp		0	0%	0.0	1.0		
MMP_FPTP	2015	338	100%	1.0	100%	0%	17.2%
kingsley		0	0%	0.0	1.8	0.0	
RcRUPR	2015	338	100%	2.3	62%	38%	10.7%
stv_huge		0	0%	0.0	1.0		
STV	2015	338	100%	26.0	23%	77%	2.4%

Region		# Tot Seats	% Seats	Avg # Seats/Region	Avg #Reg/Prov	Avg Adjust Seats / Region	
Riding	Year	# Tot Seats	% Seats	Avg # Seats/Riding	% Single	% Multiple	Comp. Gallagher
stv_med		0	0%	0.0	1.0		
STV	2015	338	100%	10.9	10%	90%	4.3%
stv_small		0	0%	0.0	2.8		
STV	2015	338	100%	4.1	5%	95%	6.5%
ru_multiples_rc2		42	11%	29.0	1.3		
RcRUPR2	2015	338	89%	4.2	5%	95%	2.2%

Appendix: Riding-Centric Proportional Representation (RCP)

Given the challenge to produce a version of RU-PR that satisfies the constraint that it can be implemented in 2019 without changing the riding boundaries that were in effect in the 2015 election, I believe that I (in collaboration with Antony Hodgson from Fair Voting BC) have found an approach (which we call Riding-Centric Proportional Representation, or RCP) that offers a number of potentially valuable features that distinguish it from the original RU-PR model:

- It produces even more proportional results
- It enables the most rural ridings to remain at their current size (no 15% increase required)
- It ensures that an MP is elected in every existing riding (avoiding the concern that MPs from different parties in a multimember district will all come from the largest population centre in a riding)
- It can simplify future Electoral Boundaries Commission processes by giving EBCs more flexibility to tune the percentage of adjustment seats without having to change electoral boundaries.
- It encourages more gender-balanced and diverse slates by providing a positive incentive for parties to run candidates in each existing riding.

How RCP Is Done:

To satisfy the requirement that existing riding boundaries do not change, and to achieve our other goals, we do the following:

Create Multi-Member Urban Ridings & Single-Member Rural Ridings: Group the existing single-member ridings into multi-member ridings where appropriate, retaining single-member ridings where deemed necessary. Note that single-member ridings will remain the same size they currently are and the existing ridings within the multi-member riding groups will continue to retain their current identity (we could give each multi-member riding a new name, if we wish). Given that existing ridings retain their identity, there is little need for single-member ridings although the model does permit them.

Identify Adjustment Seats: Instead of adding top-up seats (or expanding current ridings by ~15% to free up top-up seats), we instead designate approximately 10-15% of the seats as 'adjustment' seats. These seats should be located in the largest multi-member ridings in the province, and the adjustment seats should be distributed roughly evenly across the province (eg, ~1 adjustment seat in every grouping of 7-10 current ridings). Note that we don't designate a specific seat within a multi-member riding as an adjustment seat - we simply identify that one of the seats in that multi-member riding will serve as an adjustment seat.

Nominate Candidates: Parties would continue to nominate candidates in each existing riding (ie, major parties would continue to nominate 338 candidates).

Use Ranked Ballot: The ballot would look very much like an ordinary STV ballot in which the names on the ballot are organized in columns under party headings. Two key differences are:

Nominate in Existing Ridings: Each party would nominate as many candidates as there are seats in the multi-member riding (e.g., in a 4-seat riding, each major party would nominate 4 candidates - one in each existing single-member riding)

One Row Per Existing Riding: Each row would represent the candidates from an existing single-member riding. The ballots in each existing riding would have the most local candidates featured at the top of the ballot (perhaps highlighted by shading or colouring to emphasize this fact).

The ballot would ideally be a preferential (ranked) ballot, with voters free to indicate their preferences within and between parties. There would be no requirement to give a first preference to one of the most local candidates, though presumably most voters would do so.

Use Simple Instant Runoff Counting: Counting would be much simpler than with conventional STV counting – essentially, the count would function much like the standard Instant Runoff Counting used in most parties' leadership races, with the candidate with the fewest votes being eliminated in each round and those ballots redistributed to the next preference indicated on each ballot. Counting would proceed until there are only as many candidates left as seats available.

Tweak Counting Rule With Proviso to Elect One MP from Each Riding: To ensure that one candidate is elected in each existing riding, we add one small tweak to the counting rules: if a candidate is the last remaining candidate in their local riding, they cannot be eliminated. The effect of this rule will be to ensure that the final set of winners will include one MP from each existing riding.

Fill the Adjustment Seats: Determine which parties should get the adjustment seats using an allocation rule such as the largest remainder rule. Assign each adjustment seat in turn to the last-eliminated candidate from the party deserving an adjustment seat in the riding where that party had the most votes (after accounting for already-elected candidates from that party in each riding).